

***VOLTECH***   
***PRO SERIES***

**Pure Sine Wave Inverters**

PST1000-12 - PST1000-24

PST2000-12 - PST2000-24

PST3000-12 - PST3000-24

**INSTRUCTION  
MANUAL**

**Pure Sine Wave Inverter with Transfer Switch**

## **Please Keep This Manual For Future Reference**

For safe and optimum performance, the Inverter must be used properly. Carefully read and follow all instructions and guidelines in this manual and give special attention to the Caution and Warning statements.

### **Disclaimer**

While every precaution has been taken to ensure the accuracy of the contents of the guide, we assume no responsibility for errors or omissions. Note as well that specifications and product functionality may change without notice.

### **Important**

Please be sure to read and save the entire manual before using your Inverter.

Misuse may result in damage to the unit and/or cause harm or serious injury. Read manual in its entirety before using the unit and save manual for future reference.

# Contents

Introduction	-----1
Product Description	-----2
Feature Setting	-----3
Understanding the Front Panel & Rear Panel	-----5
Installation & Wiring	-----6
Troubleshooting	-----9
Derating	-----10
Specifications	-----11
Warranty	-----14

## INTRODUCTION

Thank you for purchasing the Inverters. With our state of the art, easy to use design, this product will offer you reliable service for providing AC power for your home, boat, caravan, 4WD or commercial vehicle. The Inverters can run many AC powered appliances when you need AC power anywhere. This manual will explain how to use this unit safely and effectively. Please read and follow these instructions and precautions carefully.

### Important Safety Information



#### WARNING

Before you install and use your Inverter, be sure to read and save these safety instructions.

- Risk of electrical shock and energy hazard. All failures should be examined by the qualified technician. Please do not remove the case of the inverter by yourself.
- Please do not install the inverter in places with high moisture or near water.
- Please do not install the inverter in places with high ambient temperature, under direct sunlight or near flame source.
- Please only connect batteries with the same brand and model number in one battery bank. Using batteries from different manufacturers or different capacity is strictly prohibited.
- Never allow a spark or flame in the vicinity of the batteries because it may generate explosive gases during normal operation.
- Make sure the air flow from the fan is not obstructed at both sides (front and back) of the inverter. Please allow at least 15cm of space.
- Please do not stack any object on the inverter.



Don't disassemble



Away from moisture



Away from fire or high temperature



Don't stack on the inverter

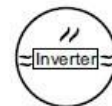

Keep good ventilation

## CE EMC INFORMATION

This equipment has been tested and found to comply with the limits for CE EMC standard. These limits are designed to provide reasonable protection against harmful interference in a residential installation. This equipment generates, uses and can radiate radio frequency energy and, if not installed and used in accordance with the instructions, may cause harmful interference to radio communications. However, there is no guarantee that interference will not occur in a particular installation. If this equipment does cause harmful interference to radio or television reception, which can be determined by turning the equipment of and on, the user is encouraged to try to correct the interference by one or more of the following measures:

- Reorient or relocate the receiving antenna.
- Increase the separation between the equipment and the receiver.
- Connect the equipment into an outlet on a circuit different from that to which the receiver is connected
- Consult the dealer or an experienced radio/TV technician for help.

## PRODUCT DESCRIPTION

### Pure Sine Wave Inverter with Transfer Switch

Pure sine wave inverter with transfer switch is a combination of an inverter and AC auto-transfer switch.

### Sine Wave Inverter Key Features

The Sine Wave Inverter utilizes advanced high frequency switching technology in the power conversion process. The circuits are similar to those used in power supplies for electronic equipments. This technology offers several benefits:

- Pure sine wave output (THD<3%)
- Auto AC Transfer Function
- Compliance to CE, SAA, FCC and E-Mark
- Low Voltage Protection (Four Stages Optional)
- High surge capability: for "hard-to-start" AC loads
- Output voltage & Frequency 50Hz or 60Hz is settable
- High efficiency up to 91%
- Power-Saving Mode
- Car Ignition Function
- 18 months global warranty
- Light weight: for easy installation

### Inverter Function

When connected properly and the power switch is turned to the "ON", the inverter draws power from a battery and delivers a true sine wave AC output voltage. If the battery voltage is within the operating range of the unit, the inverter will continue to deliver AC power to the loads connected. High and low battery voltage shutdowns will engage if the battery voltage falls out of the specified range of operation. (10-15.5 VDC on 12V models, 20-31 VDC on 24V models.)

## Automatic AC Transfer Switch

The Pure Sine Wave Inverter may be equipped with a transfer relay if specified prior to purchase. When utility AC power fails, the transfer relay is deenergized and the load is automatically transferred to the inverter output within 30 milliseconds. Once AC utility is restored, the relay energizes and the load is automatically reconnected to AC utility.

## Residual Current Device (RCD Safety Switch)

Current Device (RCD) switch detects if there is an earth leakage fault and will automatically disconnect all output power sockets protecting the user from electrocution.

The inverter has a Mains Earth Neutral (M.E. N) connection permanently installed on the inverter side of the AC Transfer switch. This allows the RCD to work correctly while on Inverter.

This system of earthing provides a reference between the Ground/Earth and the Neutral circuit allowing for detection of imbalance between the Active and Neutral Circuits in the event of a fault.

With no MEN connection in place, protective devices will not operate correctly to ensure the installation is electrically safe.

When the Transfer switch is active and allowing AC power from the Input socket to pass through to the Outlet circuits, the RCD needs to rely on the M.E.N connection of the Input Power supplied for maximum protection.

**Please note:** The majority of generators on the market do not have an M.E.N connection. If no M.E. N is present on the Input socket, the RCD will not supply the maximum protection while the Transfer Switch is active.

## SETTINGS

To understand more about the unit features, read the following section and follow the instructions to make changes to the desired setting.

### Understanding the Unit Settings

Setting	LCD	Setting	Setting Discription & Defaults
		SE0	POWER SAVE mode OFF <i>(default)</i>

Power Saving Mode	SE	SE1	You would want to enable POWER SAVE mode if the inverter is only being used periodically to power loads. This allows the inverter to draw less power from the batteries during non-use periods. The POWER SAVE mode will be activated when the output power is less than 15W. When output power is more than 20W, the inverter will automatically return to normal status. <b>The 'Status' LED slows flash Orange when Power Saving is active.</b>
Buzzer Alarm	bu	bu0	Turn off the buzzer. It only shows fault code and the buzzer doesn't alarm when the inverter has any fault.
		bu1	The buzzer works normally. It shows fault code and the buzzer alarms when the inverter has any fault. <b>(default)</b>
Low Voltage Protection Setting	Lo	Lo0	Battery voltage setting is 10.5V (12V) / 21V (24V) <b>(default)</b>
		Lo1	Battery voltage setting is 10.8V (12V) / 21.6V (24V)
		Lo2	Battery voltage setting is 11.3V (12V) / 22.6V (24V)
		Lo3	Battery voltage setting is 11.8V (12V) / 23.6V (24V)
Priority (ATS)	pr	pr0	Use as Inverter only. No Bypass function.
		pr1	Inverter automatically turns ON when AC blackout. <b>(default)</b>
		pr2	The inverter will shutdown when the utility fails, then the inverter needs to be started manually and enter into "INVERTER" mode; But Once AC utility is restored, the load is automatically reconnected to AC utility
Frequency	HZ	H50	50HZ
		H60	60HZ
Output Voltage setting	vo	v01	The output voltage setting is 220V.
		v02	The output voltage setting is 230V.
		v03	The output voltage setting is 240V.
Default	dF		Restore factory default settings.

**Remarks: factory default setting is SE0, bu1, Lo0 and pr1.**

## Operation Chart

If you want to set the above Settings , please follow instructions below.

### To Enter the setting Menu for unit setting:

To enter the unit Settings Menu, Press and hold "Power" and "Select" buttons together for about 5 seconds until a beep is heard.

### When are you in the Settings Menu:

- Pressing 'Power' button for 1 second to scroll between different setting Menus such as 'SE', 'bu', 'Lo' and 'Pr' etc.

- Pressing 'Select' button for 1 second will enter Individual setting Menu and from there you can make changes to that settings.

- The unit will EXIT to the Main Menu automatically if 'Power' or 'Select' buttons are not triggered within 5 seconds.

### To Change Settings:

- Enter the settings menu as above and scroll to the desired setting.

- Press 'Select' button for 1 second to enter Individual Setting Menu you would like to change.

- Press 'Select' button for 1 second to Scroll between different setting values.

- Press 'Select' button for 5 seconds to save set selected setting and exit to next menu.

See more details on the Below flow chart.

LEGEND:	
P	Press "Power"
5P	Hold "Power" 5 seconds
S	Press "Select"
5S	Hold "Select" 5 seconds
To program new settings	Scroll to desired settings---hold "Select" 5 seconds (5S)---record & show next setting
Exit program mode	Hold "Power" and "Select" together for 5 seconds, exit program mode.

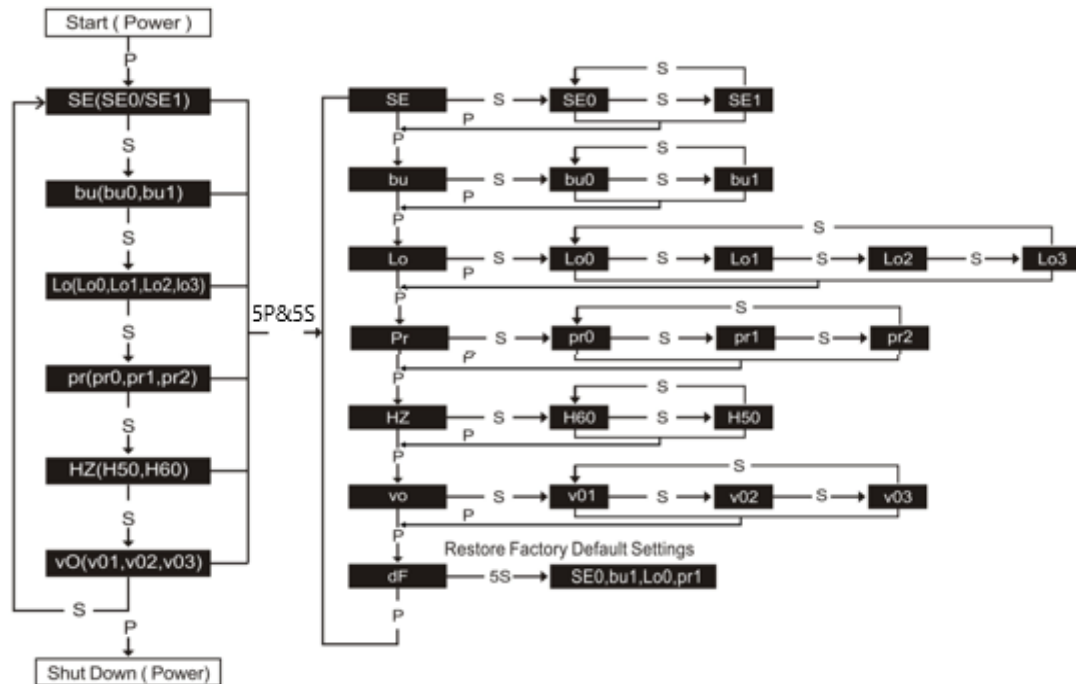

## Understanding the Display Panel, Front Panel & Rear Panel

### Display Panel

**INSTALLER'S NOTE:** The Display panel is designed to be attached to the case in 4 x different options to suit the Inverter mounting preference.

note; The LCD Display on the unit is fully detachable for remote mounting.

to install the remote in a different location use the provided 6 pin standard RJ12 cable.

a. Remove the 2 screws at the front of the Display Panel and disconnect the small RJ12 cable from the unit.

b. Fit the supplied cover plate using the two screws.

c. Install the Display panel in your desired location and connect the 6mtr RJ12 cable into the front panel RJ12 Socket and the other end of the cable to the Display Panel.

Also

To

ALSO

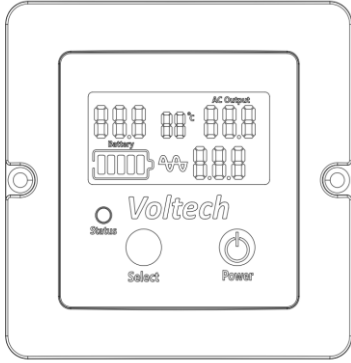
<p>Display Panel</p>		
<p>Power Button</p>	<p>Turns the inverter ON/OFF during Battery Mode.          -To turn the inverter ON: press and hold "Power" button until hearing the beep. The display will show the Display revision levels 'Dx.x' and then the Main Board revision levels 'rx.x' (where x = any number)          --To turn the inverter OFF: press "Power" button to turn the inverter OFF.</p>	
<p>Select Button</p>	<p>Check the unit setting: Press once to check or verify unit's present set functions.</p>	
<p>Status LED Light</p>	<p>Amber (Solid)</p>	<p>Battery/Inverter Mode</p>
	<p>Green (Solid)</p>	<p>Bypass Mode</p>
	<p>Amber (flashing)</p>	<p>Battery/Inverter mode and AC input is detected and unit will switch to Bypass mode within 20 seconds</p>
	<p>Red (Solid)</p>	<p>Fault. Display shows error code.</p>
<p>Display shows</p>	<p>DC Input Voltage, Operation temperature, AC Output Voltage, Battery Capacity, Waveform, Output Power (Only Inverter Mode), Output Frequency, Error Code</p>	

**Front Panel**

The Front Panel of 1000W, 2000W and 3000W Pure Sine Inverter with Auto Transfer Switch & RCD.

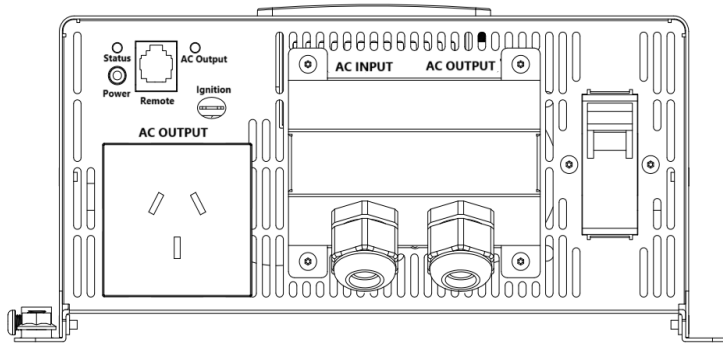

<p>Power Button</p>	<p>Turns the inverter ON/OFF during Battery Mode.          -To turn the inverter ON: press and hold "Power" button until hearing the beep. The display will show the Display revision levels 'Dx.x' and then the Main Board revision levels 'rx.x' (where x = any number)          --To turn the inverter OFF: press "Power" button to turn the inverter OFF. .</p>	
<p>Status LED Light</p>	<p>Amber (Solid)</p>	<p>Battery/Inverter Mode (Inverting Power on Outputs)</p>
	<p>Green (Solid)</p>	<p>Bypass Mode ( AC Mains Power on Outlets)</p>
	<p>Amber (flashing)</p>	<p>Battery/Inverter mode. Mains AC input has been detected and unit will switch to Bypass mode within 20 seconds.</p>
	<p>Red (Solid)</p>	<p>Fault. Display shows error code.</p>
<p>AC Output LED light</p>	<p>Solid Green whenever AC output is available.</p>	
<p>Remote Port</p>	<p>RJ12</p>	<p>Route the RJ12 cable from the unit to your desired location for the Remote LCD Controller (optional). Use the provided 6 pin straight through RJ12 cable.</p>
<p>Ignition Port (+12V Only)</p>	<p>Ignition Control Feature, Can be used to turn the Inverter On/Off via a <b>12VDC ONLY input</b> signal. (For 24V Inverters use a Voltage Divider cct or 12V source.)</p>	
<p>AC OUTPUT Socket &amp; Hardwire</p>	<p>Either or both types of Outputs can be used at the same time.</p>	
<p>AC INPUT Hardwire</p>	<p>Connect the utility power. When utility power is available, the unit is running in AC Bypass mode. AC output is supplied from the utility.</p>	
<p>RCBO (Residual Current Device)</p>	<p>Resettable AC circuit breaker &amp; Earth Leakage Device for AC output.</p>	

## Rear Panel

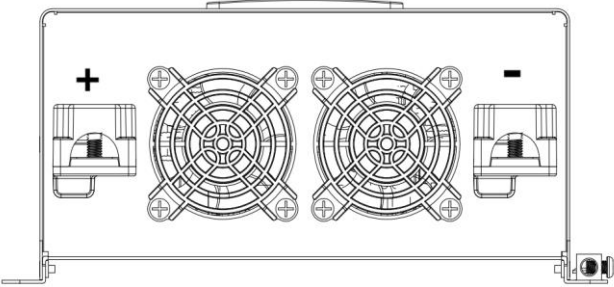
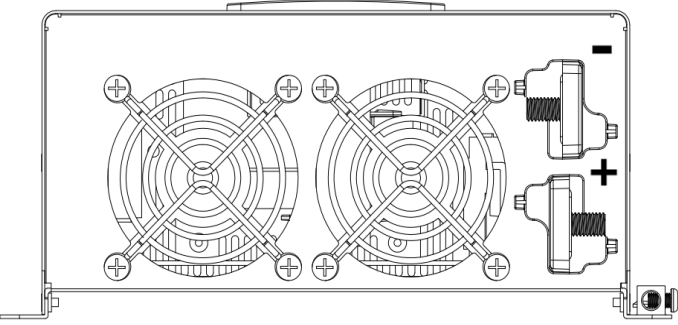
<p>The Rear Panel of 1000W Pure Sine Inverter with Transfer Switch</p>	
<p>The Rear Panel of 2000W and 3000W Pure Sine Inverter with Transfer Switch</p>	
<p>DC battery terminals</p>	<p>Connect the inverter to batteries or other power sources. Negative (-) and positive (+) DC terminals should be kept insulated to protect from accidental short circuits.</p>
<p>Variable speed cooling fan</p>	<p>Temperature and load controlled.</p>

## INSTALLATION & WIRING

**Wiring for Batteries:** Wire connections should be as short as possible and less than 1.5 meter is highly recommended. Long DC wires tend to lose efficiency and reduce the overall performances of an inverter. Make sure that suitable wires are chosen based on the rating of current. A cross-sectional area that is too small can lead to overheating, thereby causing certain dangers. Please refer to following table.

Note: Please consult our local distributors if you have any questions.

Rated Current of Equipment (amp)	Cross-section of Lead (mm <sup>2</sup> )	AWG	Suggested Wiring
16A-25A	2.5	12	
25A-32A	4	10	
32A-40A	6	8	

40A-60A	10	6	Safety Wiring Range
63A-80A	16	4	
80A-100A	25	2	
100A-125A	35	1	
≥ 125A	50	0	

Remarks:

- All DC cables require insulated multi-strand low resistance cable.
- The DC cables must be copper and must be rated 105° minimum.

Table: Suggestion for Wire Selection



**CAUTION**

Use of smaller gauge cable or longer cable length may cause the inverter to shutdown under heavy load. This may also lead to the cables melting or catching fire. This could result in death or serious injury. Choice of the cable size should also match with the rating of the DC fuse used.

**To make DC wiring connections:**



**CAUTION**

- Clean battery terminals before making connections.
- Always wear eye protection.
- Reversing the DC Input Polarity will damage the unit and cannot be repaired. Damage caused by reverse polarity connection is not covered by the warranty.

1. Connect one end of the negative DC input cable to the Inverter DC negative terminal.
2. Connect the other end of the negative DC input cable to the battery negative.
3. Connect one end of the positive DC input cable to the Inverter DC positive terminal.
4. Connect the other end of the positive DC input cable to the battery positive.

Observe the polarities carefully while performing the installation and do not reverse the polarities. And make sure all the DC connections are tight. Loose connections will overheat and could result in a potential fire hazard.

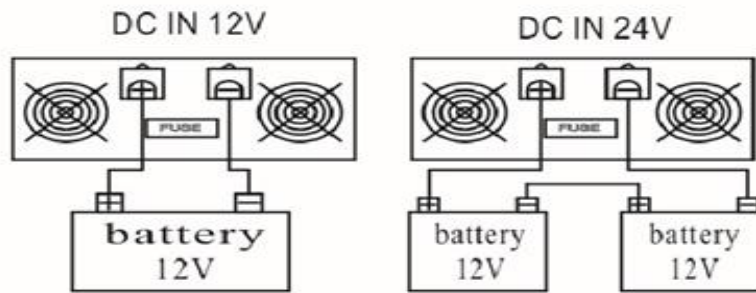

Battery connections

## 12V & 24V Battery Banks

- The use of deep cycle battery is highly recommended for power inverter application.
- For battery size, you need to identify how much and for how long the inverter has to provide AC power to the loads (based on Amps x hour energy consumption). It is recommended to purchase as much battery capacity as possible.

Following run times estimates are for reference only, based on using different battery bank sizes. Actual run times may vary depending on battery type/condition/Temp'/ etc.

	Estimate runtime on different 12V Battery Bank size				
AC Load	60AH	120AH	180AH	240AH	300AH
50 W	11 hrs.	22 hrs.	33 hrs.	44 hrs.	55 hrs.
100 W	5 hrs.	11.5 hrs.	17 hrs.	23 hrs.	29 hrs.
200 W	2.5 hrs.	5 hrs.	8 hrs.	11 hrs.	13.5 hrs.
500 W	49 mins	2 hrs.	3 hrs.	4 hrs.	5 hrs.
1000 W	15 mins	49 mins	1.5 hrs.	2 hrs.	2.5 hrs.
1500 W	8 mins	27 mins	49 mins	1 hr	1.5 hrs
2000 W	N.R.	15 mins	34 mins	49 mins	1 hrs
2600 W	N.R.	11 mins	25 mins	37 mins	49 mins
Note: N.R. - Not Recommended					

## Requirement of Installation

The unit should be mounted on a flat surface or holding rack with suitable strength. In order to ensure the lifespan of the unit, please refrain from operating in environments of high dust, high temperature or high moisture. This is a power supply with built-in DC fan. Please make sure that ventilation is not blocked.

(Note: There should be no barriers within 15cm of the ventilating holes.)

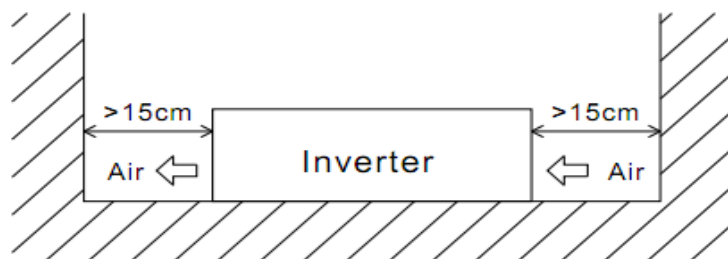

Example of Installation

### Mounting Suggestion:

There are 4 semi-circular cutout on the side flanges of the inverter. It can be used for fixing inverter onto the system enclosure. We strongly recommend horizontal installation. Please make sure the ventilation openings are free from obstruction.

## TROUBLESHOOTING

### Understanding the Error Code

Error Code	Condition	Corrective Action
01	Low voltage shutdown	Recover manually after the inverter shutdown. (The inverter will auto recover when the battery voltage goes back to a normal level within 20s.)
02	Over input voltage protection	Recover manually after the inverter shutdown. (The inverter will auto recover when the battery voltage goes back to a normal level within 20s.)
03	Over load protection	The inverter shutdown when output power is overloaded around 120%, it needs to be recovered manually.
	Short circuit protection	Manual recovery
04	Over temperature protection	The inverter will automatically return to normal status when the internal temperature drops to $80\pm 5^{\circ}\text{C}$ .
05	Low voltage alarm	Buzzer sounds and fault light turns red
06	Over load alarm	Buzzer sounds and fault light turns red when output power is overloaded around 110%. But the BUZZ and F06 code will not occur when the output power drops to a normal level within 20s.

07	Over temperature alarm	Buzzer sounds and fault light turns red when the inverter's internal temperature is higher than the limit value (90±5 °C).
08		The display will show the code F08 when the thermostats in the inverter are malfunctioning.
09	AC input overload protection	The fan will start to work when the relay temperature is up to 60±5 °C; but it will stop working when the relay temperature drops to 50±5 °C. The unit will alarm and no AC output when relay temperature is up to 75±5 °C; but it will auto recover when the relay temperature drops to normal value.

To troubleshoot the unit, please note the error code displayed on the main unit and review "Understand the Error Codes" in this section.

Control Panel Indication	Fault Condition	Solution
HIGH BATT SHUTDOWN (code: 02)	Battery voltage too high	Check the battery charging system for faults. Manually reset inverter by pressing switch "POWER"
LOW BATT SHUTDOWN (code: 01)	Battery voltage too low	Charge battery. Manually reset inverter by pressing switch "Power"
OVERLOAD SHUTDOWN (code: 03)	Battery current too high, probable AC overload	Reduce load on inverter.
OVERTEMP SHUTDOWN (Code: 04)	System over-temperature	Improve ventilation and cooling and/or reduce load on inverter.

## DERATING



### Notes on output load:

The inverter can continuously power most devices that require AC power. But for certain types of loads, the unit may not work properly.

(1) Since inductive loads or motor-based equipments require a large starting current (6~10 times of its rated current), the inverter may not start successfully with these kinds of loads.

(2). When the Loads are capacitive or rectified equipments (such as switching power supply), To ensure proper operation it is suggested to have the loads turned Off before starting the Inverter, you should increase the load only after the inverter has been started up.

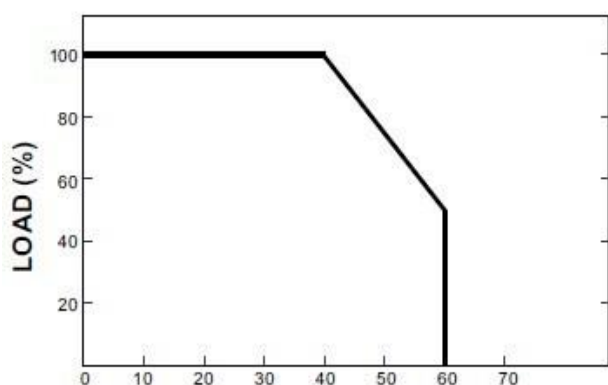

Ambient Temperature (°C)

Output Derating Curve

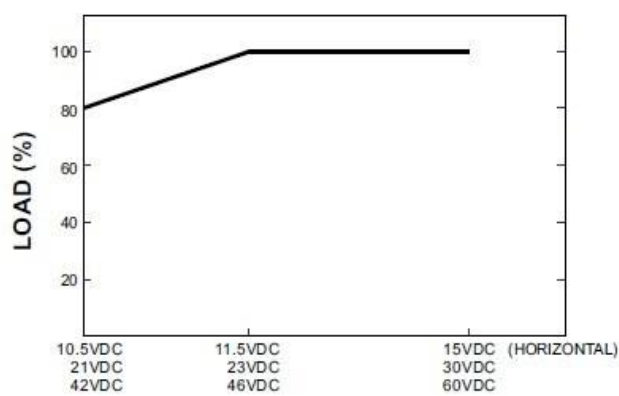

Battery Input Voltage (V)

Input Derating Curve

## SPECIFICATION

Note: Specifications are subject to change without notice.

### Main Specification of 1000W Pure Sine Inverter with Transfer Switch

Model	PST1000-12	PST1000-24
Continuous Power	1000W	
Peak Power	2000W	
DC Voltage	DC12V	DC24V
AC Voltage	220 / 230 / 240VAC ( Can be set by user )	
No Load Current Draws	1A	0.5A

Max AC Input Current	8.5A		4.5A	
Frequency	50Hz ± 0.5Hz or 60Hz ± 0.5Hz ( Can be set by user )			
Output Waveform	Pure Sine Wave			
AC Regulation	THD<3% (Linear load)			
Output Efficiency	up to 91%			
RCD Rating	10A			
Transfer relay rating	16A			
Transfer time AC to inverter and inverter to AC	Less than 30ms			
<b>DC Input Protection</b>				
DC Voltage Range	10-15.5V		20-31V	
Low Voltage Alarm	Lo0:10.5V	11V±0.3V	Lo0:21V	22V±0.3V
	Lo1:10.8V	11.3V±0.3V	Lo1:21.6V	22V±0.3V
	Lo2:11.3V	11.8V±0.3V	Lo2:22.6V	23.6V±0.3V
	Lo3:11.8V	12.3V±0.3V	Lo3:23.6V	24.6V±0.3V
Low Voltage Shut Down	Lo0:10.5V	10.5V±0.3V	Lo0:21V	21V±0.3V
	Lo1:10.8V	10.8V±0.3V	Lo1:21.6V	21.6V±0.3V
	Lo2:11.3V	11.3V±0.3V	Lo2:22.6V	22.6V±0.3V
	Lo3:11.8V	11.8V±0.3V	Lo3:23.6V	23.6V±0.3V
Low Voltage Alarm Recovery	Lo0:10.5V	11.3V±0.3V	Lo0:21V	22.6V±0.3V
	Lo1:10.8V	11.6V±0.3V	Lo1:21.6V	23.2V±0.3V
	Lo2:11.3V	12.1V±0.3V	Lo2:22.6V	24.2V±0.3V
	Lo3:11.8V	12.6V±0.3V	Lo3:23.6V	25.2V±0.3V
Low Voltage Protection Recovery	Lo0:10.5V	12V±0.3V	Lo0:21V	24V±0.3V
	Lo1:10.8V	12.3V±0.3V	Lo1:21.6V	24.6V±0.3V
	Lo2:11.3V	12.8V±0.3V	Lo2:22.6V	25.6V±0.3V
	Lo3:11.8V	12.8V±0.3V	Lo3:23.6V	25.6V±0.3V
Over Voltage Shut Down	15.7V±0.3V	31.5V±0.3V	15.7V±0.3V	31.5V±0.3V
Over Voltage Recovery	15.3V±0.3V	29.5V±0.3V	15.3V±0.3V	29.5V±0.3V
Fuse	Internal		Start	Bipolar soft-start
Working Temperature	-10°C--+50°C		Product Size	370x245x110mm
Storage Temperature	-30°C--+70°C		Cooling Way	Variable speed cooling fan

## Main Specification of 2000W Pure Sine Inverter with Transfer Switch

Model	PST2000-12	PST2000-24
Continuous Power	2000W	
Peak Power	4000W	
DC Voltage	DC12V	DC24V
AC Voltage	220 / 230 / 240VAC ( Can be set by user )	

No Load Current Draws	1A		0.5A	
Max AC Input Current	8.7A			
Frequency	50Hz ± 0.5Hz or 60Hz ± 0.5Hz ( Can be set by user )			
Output Waveform	Pure Sine Wave			
AC Regulation	THD<3% (Linear load)			
Output Efficiency	up to 91%			
RCD Rating	16A			
Transfer relay rating	30A			
Transfer time AC to inverter and inverter to AC	Less than 30ms			
<b>DC Input Protection</b>				
DC Voltage Range	10-15.5V		20-31V	
Low Voltage Alarm	Lo0:10.5V	11V±0.3V	Lo0:21V	22V±0.3V
	Lo1:10.8V	11.3V±0.3V	Lo1:21.6V	22V±0.3V
	Lo2:11.3V	11.8V±0.3V	Lo2:22.6V	23.6V±0.3V
	Lo3:11.8V	12.3V±0.3V	Lo3:23.6V	24.6V±0.3V
Low Voltage Shut Down	Lo0:10.5V	10.5V±0.3V	Lo0:21V	21V±0.3V
	Lo1:10.8V	10.8V±0.3V	Lo1:21.6V	21.6V±0.3V
	Lo2:11.3V	11.3V±0.3V	Lo2:22.6V	22.6V±0.3V
	Lo3:11.8V	11.8V±0.3V	Lo3:23.6V	23.6V±0.3V
Low Voltage Alarm Recovery	Lo0:10.5V	11.3V±0.3V	Lo0:21V	22.6V±0.3V
	Lo1:10.8V	11.6V±0.3V	Lo1:21.6V	23.2V±0.3V
	Lo2:11.3V	12.1V±0.3V	Lo2:22.6V	24.2V±0.3V
	Lo3:11.8V	12.6V±0.3V	Lo3:23.6V	25.2V±0.3V
Low Voltage Protection Recovery	Lo0:10.5V	12V±0.3V	Lo0:21V	24V±0.3V
	Lo1:10.8V	12.3V±0.3V	Lo1:21.6V	24.6V±0.3V
	Lo2:11.3V	12.8V±0.3V	Lo2:22.6V	25.6V±0.3V
	Lo3:11.8V	12.8V±0.3V	Lo3:23.6V	25.6V±0.3V
Over Voltage Shut Down	15.7V±0.3V	31.5V±0.3V	15.7V±0.3V	31.5V±0.3V
Over Voltage Recovery	15.3V±0.3V	29.5V±0.3V	15.3V±0.3V	29.5V±0.3V
Fuse	Internal		Start	Bipolar soft-start
Working Temperature	-10°C--+50°C		Product Size	380x245x110mm
Storage Temperature	-30°C--+70°C		Cooling Way	Variable speed cooling fan

## Main Specification of 3000W and 4000W Pure Sine Inverter with Transfer Switch

Model	PST3000-12	PST3000-24
Continuous Power	3000W	

Peak Power	6000W			
DC Voltage	DC12V		DC24V	
AC Voltage	220 / 230 / 240VAC ( Can be set by user )			
No Load Current Draws	1.2A		0.5A	
Max AC Input Current	13A			
Frequency	50Hz ± 0.5Hz or 60Hz ± 0.5Hz ( Can be set by user )			
Output Waveform	Pure Sine Wave			
AC Regulation	THD<3% (Linear load)			
Output Efficiency	up to 91%			
RCD Rating	20A			
Transfer relay rating	30A		35A	
Transfer time AC to inverter and inverter to AC	Less than 30ms			
<b>DC Input Protection</b>				
DC Voltage Range	10-15.5V		20-31V	
Low Voltage Alarm	Lo0:10.5V	11V±0.3V	Lo0:21V	22V±0.3V
	Lo1:10.8V	11.3V±0.3V	Lo1:21.6V	22V±0.3V
	Lo2:11.3V	11.8V±0.3V	Lo2:22.6V	23.6V±0.3V
	Lo3:11.8V	12.3V±0.3V	Lo3:23.6V	24.6V±0.3V
Low Voltage Shut Down	Lo0:10.5V	10.5V±0.3V	Lo0:21V	21V±0.3V
	Lo1:10.8V	10.8V±0.3V	Lo1:21.6V	21.6V±0.3V
	Lo2:11.3V	11.3V±0.3V	Lo2:22.6V	22.6V±0.3V
	Lo3:11.8V	11.8V±0.3V	Lo3:23.6V	23.6V±0.3V
Low Voltage Alarm Recovery	Lo0:10.5V	11.3V±0.3V	Lo0:21V	22.6V±0.3V
	Lo1:10.8V	11.6V±0.3V	Lo1:21.6V	23.2V±0.3V
	Lo2:11.3V	12.1V±0.3V	Lo2:22.6V	24.2V±0.3V
	Lo3:11.8V	12.6V±0.3V	Lo3:23.6V	25.2V±0.3V
Low Voltage Protection Recovery	Lo0:10.5V	12V±0.3V	Lo0:21V	24V±0.3V
	Lo1:10.8V	12.3V±0.3V	Lo1:21.6V	24.6V±0.3V
	Lo2:11.3V	12.8V±0.3V	Lo2:22.6V	25.6V±0.3V
	Lo3:11.8V	12.8V±0.3V	Lo3:23.6V	25.6V±0.3V
Over Voltage Shut Down	15.7V±0.3V	31.5V±0.3V	15.7V±0.3V	31.5V±0.3V
Over Voltage Recovery	15.3V±0.3V	29.5V±0.3V	15.3V±0.3V	29.5V±0.3V
Fuse	Internal		Start	Bipolar soft-start
Working Temperature	-10°C--+50°C		Product Size	410x245x110mm
Storage Temperature	-30°C--+70°C		Cooling Way	Variable speed cooling fan

# WARRANTY

## 24-month Limited Warranty

We warrant the Inverter to be free from the defects and/or failures as specified below for a period not exceeding 24 months from the date of sale to the original customer.

- Defects and/or failures due to manufacturing.
- Defects and or failures due to materials.
- Non-conformity to specifications due to faulty manufacturing and/or inspection processes.

If the Inverter fails to conform to this warranty, we will repair or replace at our discretion.

## Warranty Exclusions

1. No claim based on the limited warranty may be brought after the applicable warranty period. Any delivery of additional inverter or the repair or replacement of the inverter would not extend the original terms of this Limited Warranty.
2. This Limited Warranty shall not cover defects and/or failures of the inverter from the following causes even though such defects and/or failures are discovered within the applicable warranty period.
  - a) Defects and/or failures caused by devices and/or parts other than the inverter or by mounting methods of such devices and/or parts.
  - b) Defects and/or failures caused by defective wiring, installation, or handling.
  - c) Defects and/or failures caused by installations not in conformance with inverter specifications, installation manuals, operation manuals, or labels attached to the inverter.
  - d) Defects and/or failures caused by unauthorized maintenance, operation or modification
  - e) Defects and/or failures caused by external accidents such as fire, explosion, and civil disorder.
  - f) Defects and/or failures caused by natural forces, acts of God or force majeure events and other unforeseen hurricanes, tornadoes, volcanic action, floods, tsunami, lightning, snow, etc.
  - g) Defects and/or failures caused by smoke and/or other pollution, salt damage, acid rain, etc.

**NOTE: No part of this warranty excludes or is meant to imply an exclusion to any rights the User may have under applicable local laws.**

We reserve the right to make any modifications to the product without prior notification. E & OE Ver.1  
2025